



TL8



TL10



TL12



TL12V2

Product Features & Specifications

ENGINE

- EPA Interim Tier 4 Compliant
- Turbocharged
- DOC+DPF Exhaust After Treatment
- Automatic Fuel Bleed System
- Active Power Control Power Management System
- Dual Element Air Filter with Pre-Cleaner

ELECTRICAL

- Multi-Informational Display
- Sealed Rocker Switches
- 12 volt System with 80 amp Alternator
- Halogen Work Lights: Two Front and Two Rear
- Engine Preheat
- Hour Meter
- Back-up Alarm

TAKEUCHI FLEET MANAGEMENT

- 2 Year Standard Service
- Minimize Downtime
- Remote Diagnostics
- Utilization Tracking
- Proactive Maintenance
- Control Costs

UNDERCARRIAGE AND FRAME

- Permanently Sealed Track Rollers with Metal Face Seals
- Fully Welded One Piece Track Frame
- Two-Speed Travel
- 17.7" Rubber Track
- Grease Type Track Adjuster

OPERATOR'S STATION

- Tilt-up Operator's Station
- Deluxe High Back Suspension Seat
- Rear Pivoting Lap Bar with Arm Rest
- ROPS / FOPS Structure
- Retractable 2" Seat Belt
- Pressurized Cab with Roll-up Door, A/C, Heat, Defrost and Front Wiper (optional)
- AM / FM / MP3 Radio with NOAA Weatherband (optional)
- Retractable 3" Seat Belt (optional)
- 3 Point Retractable Seat Belt (optional)
- Polycarbonate Door and Top Guard (High Flow Only)

HYDRAULIC & WORKING EQUIPMENT

- Pilot Proportional Hydraulic Controls
- Boom Float with Detent
- Cushioned Boom Cylinders
- Hydraulic Self Leveling
- Pressure Relieving Flat Faced Coupler Body
- 14-Pin Connector
- Mechanical Quick Coupler
- Hydraulic Quick Coupler
 - Cab - Standard Equipment
 - Canopy - optional
- High Flow Auxiliary Hydraulics 36 gpm (optional)
- Secondary Auxiliary Circuit 17 gpm (optional)
- Ride Control (optional)
- Pattern Change Valve (optional)

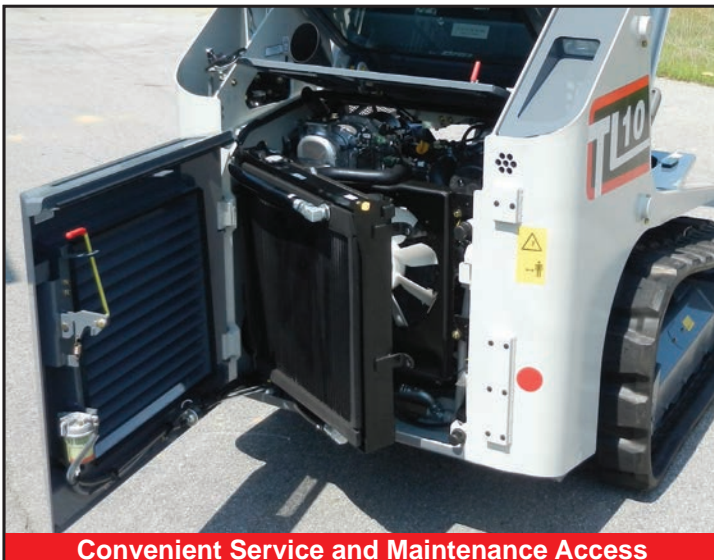

Convenient Service and Maintenance Access



Integrated Undercarriage

TOUGH, RUGGED, EFFICIENT



Fully Welded Frame



Steel on Steel



Active Power Control

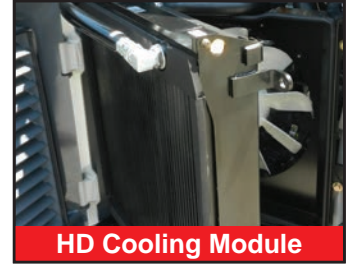

HD Cooling Module

The TL10 is engineered to deliver excellent power and performance. It features a powerful 92.0 HP engine coupled with double reduction planetary drives enabling it to work in extreme applications. The radial lift design allows it to exceed in excavation and grading applications while providing excellent mid-height reach. The operator is able to monitor machine functions and performance via multi-information display while precisely controlling travel and loader functions with pilot operated joysticks. A deluxe high back suspension seat reduces fatigue and delivers excellent comfort and

visibility while on the job. The operator's cabin is spacious and the available cab has an overhead door that can be opened or closed while operating the TL10. The heavy duty rear door protects vital engine and hydraulic components and has a locking mechanism to keep it open while performing daily inspections. The high capacity cooling module features a side-by-side radiator and oil cooler that allow the TL10 to operate efficiently, while remaining easy to inspect and clean. With the cabin tilted the inside of the frame can be inspected with easy access to maintenance points.



Spacious operator's platform with easy to reach controls and switches.

OPERATING PERFORMANCE

Operating Weight - Canopy	10,320 lb	(4,680 kg)
Cab	10,515 lb	(4,770 kg)
Tipping Load	6,867 lb	(3,115 kg)
Rated Operating Capacity, SAE J818*	2,403 lb	(1,090 kg)
w/ Optional Counter Weight	2,723 lb	(1,235 kg)
Operating Load at 50% of Tipping Load	3,434 lb	(1,558 kg)
Bucket Breakout Force	7,400 lb	(3,357 kg)
Lift Arm Breakout Force	7,425 lb	(3,368 kg)
Traction Force	11,060 lb	(5,017 kg)
Ground Pressure - Canopy	4.4 psi	(30.1 kPa)
Ground Pressure - Cab	4.5 psi	(30.7 kPa)
Travel speed - Low	4.6 mph	(7.4 km/hr)
High	7.2 mph	(11.6 km/hr)

* Operating capacity of compact track loaders is rated according to SAE J818 at no more than 35% of the tipping load

ENGINE

Make / Model	Kubota / V3800CR-Turbo	
Engine Displacement	230 cu in	(3.8 L)
Horsepower @ 2,400 rpm	92.0 hp	(68.6 kW)
Maximum Torque @ 1,500 rpm	247 ft-lb	(335 Nm)

FLUID CAPACITIES

Engine Lubrication	13.9 qt	(13.2 L)
Cooling System	16.4 qt	(15.5 L)
Fuel Tank Capacity	23.8 gal	(90.0 L)
Fuel Consumption (65% of Full Load)	3.3 gal/hr	(12.7 L /hr)
Hydraulic Reservoir Capacity	12.7 gal	(48.0 L)
Hydraulic System Capacity	19.5 gal	(74.0 L)

HYDRAULIC SYSTEM

Auxiliary Flow - Primary Circuit	20.0 gpm	(75.0 Lpm)
Auxiliary Flow - High Flow (optional)	36.0 gpm	(137.0 Lpm)
Auxiliary Flow - Secondary Circuit (optional)	17.0 gpm	(64.5 Lpm)
Hydraulic System Pressure	3,046 psi	(21.0 MPa)



LCD Display



Pilot Controls



Overhead Door



Double Reduction Drives

ATTACHMENTS

Takeuchi now offers attachments for all of your Takeuchi equipment. See your authorized Takeuchi dealer for additional information and attachment options.



Grapple - Scrap



Dozer Blades



Pallet Forks



Trenchers

TL10 Compact Track Loader

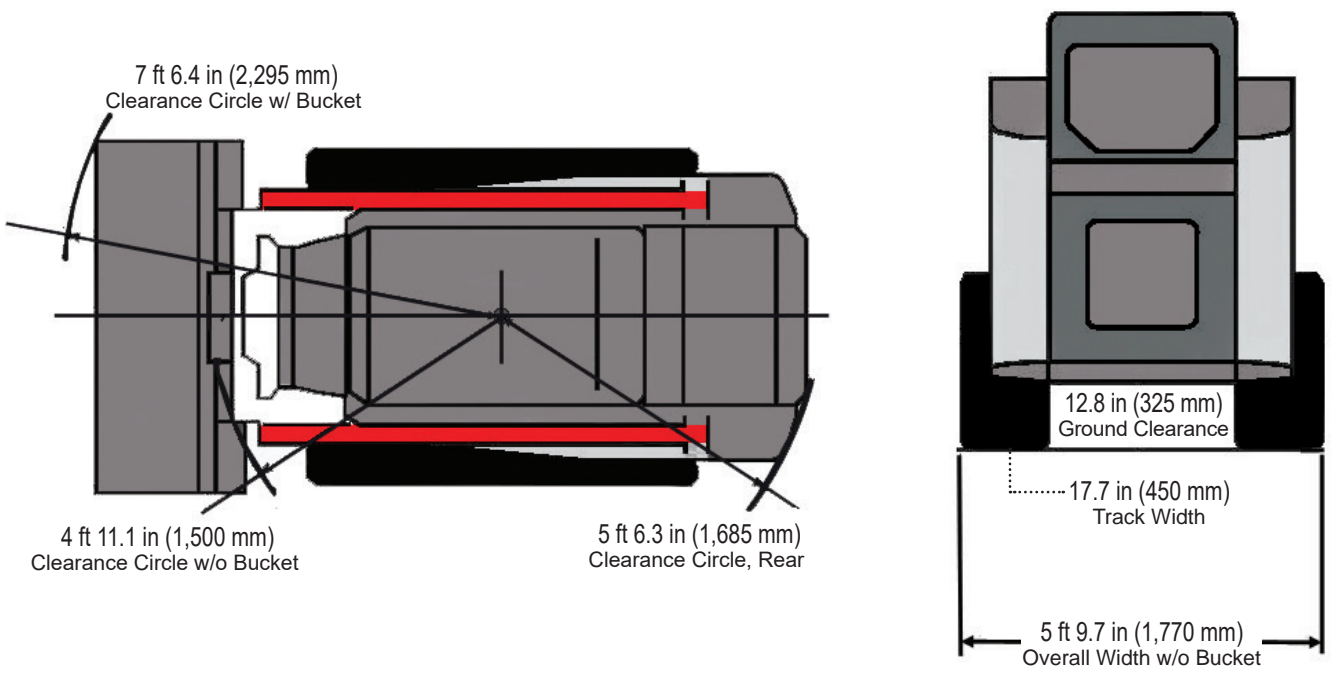
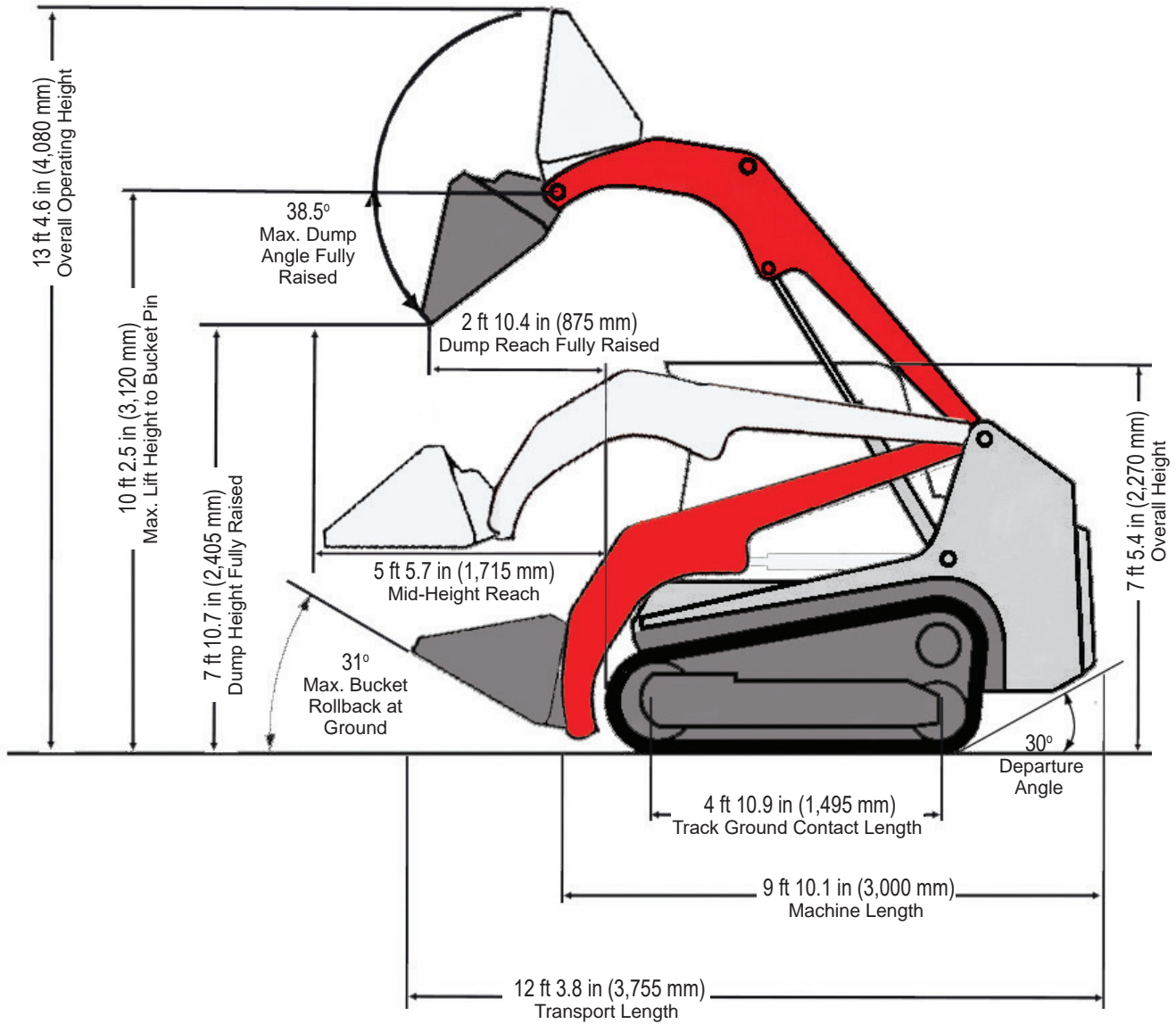



2 YEAR
2,000 HOUR
FULL MACHINE
WARRANTY



© 2016 Takeuchi Manufacturing (U.S.), Ltd. All Rights Reserved. Printed in the U.S.A. In accordance with our established policy of continued improvement, specifications and features are subject to change without notice. Pictures may show options other than standard equipment.

FORM: TL10 Compact Track Loader Spec Sheet July 2016
(TFM) s/n 201003094 (TFM) s/n 201003096 ~

TAKEUCHI
Those in the know, know Takeuchi